

Lucjan Gazda¹, Mykola Bevz²

**MATERIALS AND ARCHITECTURAL DETAILS
FROM NATURAL AND ARTIFICIAL STONE OF KING DANIEL
ROMANOVICH'S XIII CENTURY RESIDENCE IN CHOLM**

¹*Department of Geotechnics, Faculty of Civil Engineering and Architecture,
Lublin University of Technology
ORCID 0000-0003-0821-4348
l.gazda@pollub.pl*

²*Department of Build Conservation, Faculty of Civil Engineering
and Architecture, Lublin University of Technology, Department
of Architecture and Conservation, Lviv Polytechnic National University,
ORCID 0000-0003-1513-7045
bevzmist@polynet.lviv.ua*

Received: 07.06.2019 / Revised: 12.08.2019 / Accepted: 14.08.2019

© Gazda L., Bevz M., Buko A., Golub S., 2019

Abstract: Materials obtained during archaeological excavations on the place of castle in the city of Cholm (today Chełm in Poland), in the area of king Daniel's 13th century residential complex, have been subject to examination. They are in the forms of bricks and glazed tiles, as well as sizeable shapeless and purposeless accumulations indicating post-manufacturing remains. The materials are white, green and multi-colored. They refer to Halychian alabasters and green glaukonite from Cholm, which were originally used there. The examination of white materials was performed. The conducted examination indicated that the materials in question were manufactured using other than ceramic technologies, but similar to the ones used to produce silicate materials nowadays. As raw materials, chalk and biogenic silica obtained from a horsetail were used. The petrification procedure was conducted in hydrothermal conditions. As a result a material structurally similar to marble was obtained.

Key words: archaeological excavations, architectural details, natural, stone, artificial stone, construction of residence, Cholm (Chełm), XIII century.

Problem statement

Presented work is part of the project "The northern part of the princely residential complex in Chełm" (number 2014/13 / B / HS3 / 04930), financed by the National Science Center and implemented by The Institute of Archeology and Ethnology of the Polish Academy of Sciences in Warsaw under the direction of professor Andrzej Buko.

The foundation of capital city of Cholm (Chełm, in polish language) in the thirties of the 13th century by Daniel Romanowich (1201–1264) was most likely realized from scratch, within the period of stormy political and military turbulences in Europe taking place in the first part of XIII century. The occupation of Constantinople by crusaders of the fourth crusade resulted in exerting strong influences of Latin culture on the Halych-Wolodymyria Duchy virtually from all the sides (Voytovych, 2014). In the architecture, it was the time

of fully matured Romanesque and the breakthrough of Gothic technical and technological solutions. The use of white and green stone in the architectural detail of St John Chrysostom's Church (Halych-Wolhynia Chronicle) within Cholm acropolis was not accidental. The excerpt from Halych-Wolhynia Chronicles describing St Chrysostom's Church: "... He built St. John's Orthodox Church to be outstanding and flawless. Its structure was as following. Arcades 4, there was a vault from every corner, and their foundation on four human heads created by some master. Three windows, embellished by Roman glass (stained glass windows). Approaching the altar, there are two columns, all made from stone, on which there are an arcade and a dome decorated by golden stars in a glaze background. Its inner floor (it relates to the orthodox church) was cast in copper and pure lead gleaming like a mirror. Its two doors, ornamented by Halych white and green hewn stone from Cholm, were sculptured by a master called Avdiy (with) ornaments (in) all colors and gold. At their front (i.e. in the west portal) there was Savior, and at the north part, St John who aroused the feeling of astonishment in viewers" (Buko, 2016, p. 224).

The description in chronicle proves that the architectural and structural solution of a building was made at the highest technical and artistic level of its own time. The use of stained glass windows, stone sculpture (heads on columns hewn from whole stone), gold-plated polychrome, Cholm hewn green and Halych white stones in the decoration of door portals, ornaments in all colors and gold, the creation of floor in the unique way from plates cast in copper and lead - demonstrate that it was architectural and artistic action focused on obtaining the ideological result. It may be possible that the location itself in the area where green glaukonite meets white chalk was the stimulus for the implementation of this program. The sacral, royal and representative objects of early Byzantium Christianity, the Empire of Charlemagne, or finally, architecturally perfect Roman cathedrals, especially the ones that were inspired by the Pisan School formed in the second part of 12th century, all were arranged in green and white colors. Consequently, in such a context, the special attention shall be paid to the scale and direction of urban and building actions of Daniel Romanowich who founds the series of new towns, builds a new capital city (the action having no analogy in the east European history of the 13th century), builds in a very short time four new temples in Cholm, and after the fire in 1256 rebuilds them. The very significant professional and technical issue described in the chronicle which caused rapid development and high technological level of civil engineering in Cholm – "... Daniel saw that God helps this place, he started calling craftsmans – Germans, Ruthenians, different tribes, Poles went day by day and youths, and all kinds of masters escaped Tartars, saddlers and archers, and thulnics (producers of quivers), blacksmiths of iron and copper, and silver, and there appeared life and they filled courts around the town, fields, villages. He built the St John Orthodox Church to be beautiful and ideal" (Buko, 2016, p. 224). This church could be made as a result of construction, technological and artistic experience connections of professionals from Ruthenia, Poland and other parts of Europe. It is most likely that there was the atmosphere of healthy competition and experimentation (Bevz et al., 2015). The chemical and petrographic research on mortars used in the construction of other King Daniel's facility in Cholm – the Cathedral Church of the Blessed Mother of God (Hutzuliak, Shevchenko, 2015, p. 196–206), confirms the experiments with construction materials in the 13th century.

Architectural decoration connecting the green of Cholm glaukonite and the white of Halych alabaster brought Cholm to the sophisticated Byzantium patterns and Roman Europe, familiar to Daniel from direct and indirect connections (Dąbrowski, 2012). Materials, used to the implementation of this architectural and technical establishment, were yet poorly known (Halych), and in the case of glaukonite, not verified in use at all. Alabaster turned out to be not resistant to high temperatures of fire which devoured acropolis facilities in 1256. Similarly, glaukonite proved to be not resistant to atmospherical factors, intensified by the action of fire. The problem in the recreation and maintenance of the concept of these ideologies during the reconstruction after the destruction, was considerable dismissal of Cholm from the sources of approved construction stone materials applied to Roman buildings preserved until now. For instance, white and green marbles as well as Tuscan green serpentinites. As far as, there were the resources of green glaukonite at the disposal of then investors, a white stone posed the problem. It was most likely that the expensive transportation of alabaster was not repeated from the regions of Halych, which failed in the first uses, yet it could possibly be unavailable due to political reasons (Dąbrowski, 2012).

Presentation the materials of studies

Building materials and architectural details from natural stone

Presentation of high skills and an excellent showcase of the Cholm stonemason's craft are architectural details made of glaukonitite and limestone – vertical profiled elements of the pillars (portal), elegant corner locks, archives of the portal (or window frame) made of glaukonitite, as well as limestone carved fragment head with a palette motif perfectly and delicately carved.

Table 1

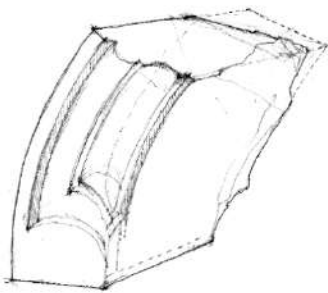
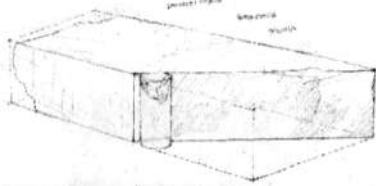
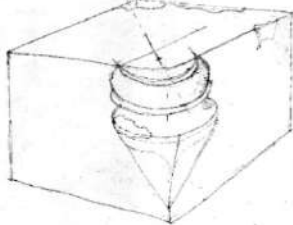
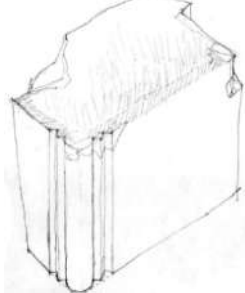
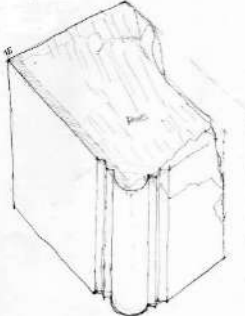
	№	Description of details	Drawing of details	Material and dimensions of the detail
1	2	3	4	5
Stone architectural details from the archaeological studies	1	Fragment of archivolt of arch. The face is profiled with a quarter fillet, half roll and base		glaukonitite
Stone architectural details from the archaeological studies of King Daniel's Castle (a study led by A. Buko)	2	Glaukonitite block with sloping surface and three-quarter roller		glaukonitite
	3	Corner block with bracket under the column		glaukonitite
	4	Glaukonitite corner block with half column and twin flutes on both sides and with sloping back face		glaukonitite
	5	Glaukonitite corner block with half column and double flutes; wide		glaukonitite

Continuation of table 1

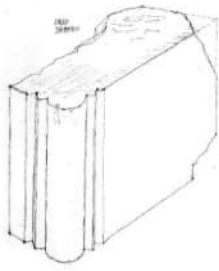
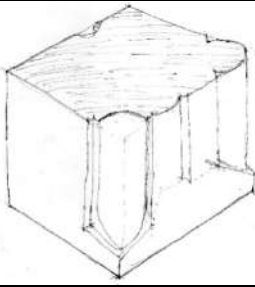
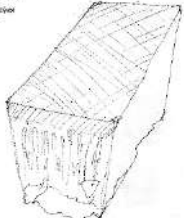
1	2	3	4	5
	6	Glaukonitite block with half column and double flutes on both sides; narrow.		glaukonitite
	7	Glaukonitite block, rectangular, profiled with two nozzles – half roll and quarter fillet		glaukonitite 425×350×350 (палац)
	8	Glaukonitite block with sloping lateral surfaces. The upper surface is sanded		glaukonitite

Gesso building blocks of glaukonitite stone

A large number of glauconitic stones have been found in excavations. It acted as building material for walls in the form of hewn blocks. Such blocks can be divided into two groups: 1 – blocks in the shape of a parallelepiped and surfaces are sanded on all sides; 2 – blocks in the form close to the parallelepiped, which are cut and sanded only on the front; and the other sides have a broken surface and rough. The peculiarity is that these blocks were often reused in later buildings.

Table 2

Block No.	Gesso building blocks of glauconitic stone	D length	H height	W width
1	2	3	4	5
13	ordinary, rectangular	210	145	270
	ordinary, rectangular	355	280	295
25	ordinary, rectangular	410	210	250
	ordinary, rectangular	210	130	
20	ordinary, rectangular	270	230	
19	ordinary, rectangular	210	145	240
8	ordinary, rectangular	284	210	210
14	the surface is stuck	215	135	123–135
	ordinary, rectangular	223	150	150
16	rounded	–	110	160
33	oblique surface	400	200–210	230
13	oblique surface	280	215	190
4?	slanting surfaces	273	150	170
20	ordinary, rectangular	250?	190	230?

Continuation of table 2

1	2	3	4	5
21	ordinary, rectangular	–	80	–
30	trapeze	310-110	150	340
	limestone, ordinary, rectangular	210	150	200?
	ordinary, rectangular	–	80	–
4?	ordinary, rectangular	–	130	–
30?	bar form	280?	130	130

From the information in Table 2, the most common sizes of stone blocks are – blocks height of 130–150 mm; less common blocks 190–210 mm high. A known feature of Romanesque construction is the use of stone wall technology “opus emplectum”. Masonry in similar technology requires the use of inverted wall positions (internal and external line of blocks) of well-cut stone blocks of equal height. The horizontal layers of blocks may have each of their own height dimensions and differ in the height of the strips in the wall structure, but it is important to maintain the block height standard in the layer. Block length, however, does not play a key position in bricklaying. It can be any. The table shows that the dimensions given are in certain standards. We can conclude that the walls of the buildings of castle in Cholm most often used layers of blocks with a height of 130–150, 210–230, 270–280 mm.

Carved architectural elements of glaukonitite stone

Glaukonitite stone is also found in the form of architectural details with carved elements. As a result of archaeological research, about 50 such details have been identified today. Some of them (about 20 details) belong to the so-called P. Pokryshkin collection – from excavations made in 1911–12 in the southern part of the hill. The rest of the details have been unearthed in the last 8 years.

A separate group consists of hewn blocks having one or two beveled surfaces. These are the elements of window or door, that formed the sloping planes of the glyphs. There are several such details (Table 1). First of all, it is a glaukonitite block with a sloping surface and a three-quarter roller. The most probable version is that it is a corner internal fragment of the window glyph. In Romanesque architecture windows with a roller or a half-roll in the framing of openings were very popular. An example of such is the preserved window in the Presbytery of the church in Imielno [Z. Swiechowski, s. 115].

An interesting is a glauconitic block with two sloping surfaces on the long side (Table 1; p. 8). The smooth upper rectangular sanded surface indicates that it is an element of a granular column or a rounded vertical wall. The scorched layer on the face confirms this, indicating that the block was interior.

All these architectural details can be divided into several groups:

- The largest group is the profiled corner blocks with a half-roll (there are 8 in Pokryshkin excavations and 7 new); (p. 4–6 in Table 1);
- Another group is profiled blocks with quarter fillet, half roll and vertical rods (1 new block and 3 blocks in Pokryshkin's collection); (p. 7 in Table 1);
- Curvilinear blocks with quarter fillets (three found); they were part of the archives of the perspective portal arch.

Analysis of the architectural forms of these details allows to draw conclusions about their belonging to the following parts of the castle buildings:

Prospective Romanesque portal. A number of details indicate that the Romanesque architectural tradition of constructing an entrance to the main buildings in the form of a prospective portal was realized at King Daniel's castle. It is possible to assume that in such forms the main entrance to the castle church of St. Ivan Chrysostom was erected. The presence of portals of such forms and their architecture is evidenced by glauconitic details both from the Pokryshkin collection and from the excavations of 2015–2017.

We present a hypothetical reconstruction of the plan and the facade of portal that adorned one of the castle buildings (Fig. 13). The reconstruction was performed on the basis of the analysis of the sizes and shapes of architectural details.

Chronicle information that the portal in the church of St. Ivan Chrysostom was made of green and white stone and is supported by indirect evidence. Most of the details we attribute to its structural elements are made of green glaukonitite stone. But in the collection we have a fragment of a carved capitul of white limestone and a small fragment of a profiled arch of great radius. We can assume that they belonged to the portal. One can hypothesize that white was the eaves of the portal impost as well as one or two bands of archivolts of the semicircular top of the portal.

Fragment of a thread of a carved white stone capitul or a corner element of cornice. This is a small piece of detail, measuring only 90x50 mm. It has symmetrically made two curls and rectangular simple abacus. The abacus belt has a height of 42 mm (Fig. 1). The detail features a very delicate embossing and delicately sanded limestone surface. The carved shape of the curl with the through drilled holes has intarsia – inserts of green glaukonitite. This is a very original artistic decoration, which is not found in other Romanesque monuments in Poland and Ukraine.

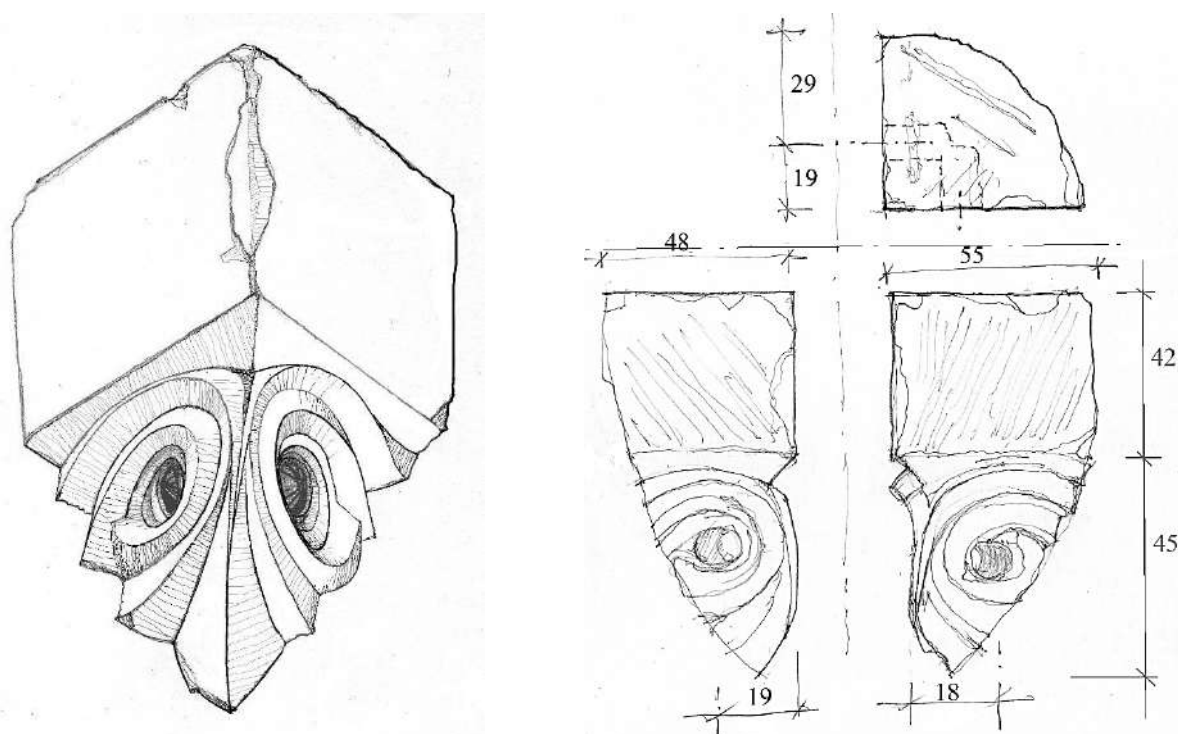

Fig. 1. Fragment of a carved detail of white limestone (fragment of the capital? Excavation CH/G/W-67/2016) with drilled holes and inserts of green glaukonitite sandstone (prepared by M. Bevz)

Building materials from artificial stone

Last archeological studies of foundation relics of the Cathedral Orthodox Church of the Blessed Mother of God in Krylos-Halych also demonstrate the alteration of construction approach in this facility in the XII–XIII centuries. Within the first stage, the cathedra was built from the white alabaster stone, then it was widen and rebuilt using the white limestone. This technological change took place as result of state evaluation and failure of the first material (Lukomskyi, Bevz, 2012, p. 26).

The lack of white stone resource in Cholm caused the demand for experimenting with petrification of chalk – soft rock abundantly available locally. The beginning of intensive exploitation of chalk in Cholm came in the 13th century. The use of limestone from baked chalk to mortars gave the knowledge that traditional heating or sintering did not bond loose structure of chalk, but it led to the creation of quicklime, air binder. There was the demand for ‘the philosopher’s stone’ necessary to transmutation. Since the 11th century, white porcelain, which had to inspire the creation of artificial white stones, has been known in Europe through the contacts with the Muslim world. White materials, found during archeological studies (Gołub, 2013) were

considered so far to be ceramic, however, during more thorough analysis, they turned out to be materials obtained from chalk, and not from white firing clays.

The research study on petrification and mineral materials filling this “alchemic” retort is performed in this article. According to the obtained results, it can be stated that within the frame of conducted experiments, the petrification of chalk with the use of active biogenic silica contained in a horsetail could be carried out, conducting the process in the hydrothermal conditions.

The materials obtained from the eastern profile of excavation no. 23 were subjected to analysis, where the object of distinctly outlined rectangular shape and vague purpose was initially documented (Fig. 2, from the left), which is accompanied by intentional accumulation of chalk (Fig. 2, from the right). This object is located beyond residential arrangements at the east bank. Archeologically, they can be dated for the 2nd or 3rd functioning phase of Daniel’s residential and sacral complex, after the destruction of outer walls and raising the ground level, so after the fire from 1256.



Fig. 2. Eastern wall of trench no. 23 within the residential and sacral complex at Wysoka Gorka in Cholm (photo S. Golub). Retort synthesis of limestone from chalk (left) and chalk raw material (right)

The samples from the object, which were operationally called as retort (Fig. 2, from the left), were taken to the research. At the upper part of the object, there is little modified white and grey chalk (Fig. 3, *a*), below light white and grey raw material, harder and more compact than chalk, with distinct replicas of plants stems of segment structure and longitudinal ribs. These replicas have the form of longitudinal negatives as well as longitudinal and transversal cross-sections of stems and leaves of plants morphologically corresponding to a horsetail (*Equisetum* L.) (Fig. 3, *b*). The organic substance has not been preserved. Inner and bottom parts of retort are filled with hard, structurally homogeneous (microcrystal) light grey and white material, cracked of distinct shell and an irregular sharp-edged burring fracture (Fig. 3, *c*).

This material at the macroscopic view (structure, sound during impact, strength to stroke and hardness) can be treated as well sintered white ceramic. However, the reaction itself with hydrochloric acid clearly indicates that this material is almost purely carbonate. Thus, this material has got the form similar to rocky limestone, obtained by no means in the technological process, it is not a rock but an artificial stone. The sequence of these materials, within the area of the same object (retort) is most likely, the record of local

petrification technology of writing chalk, useless as a construction stone, hard stone material, similar to the properties of rocky limestone applied to contemporaneous objects e.g. of Cracow or imported marbles. Without a doubt, they could also replace white Halych stones (alabaster) which were subject to destruction in the fire of the first buildings of complex (Gazda, 2016).

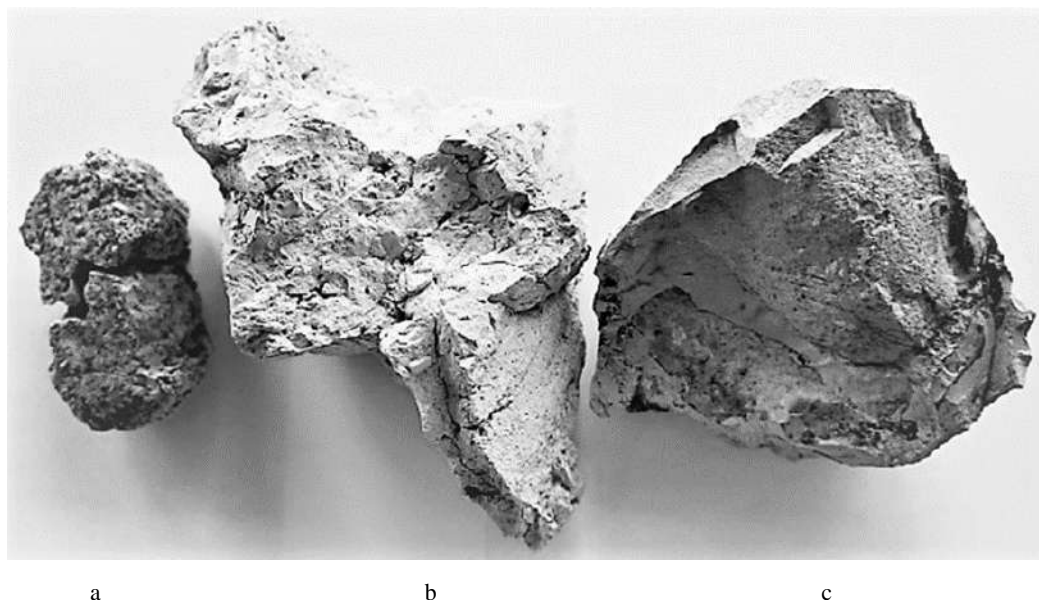

Fig. 3. Sequence of materials and materials from the retort: writing chalk (a), partially modified chalk with horseshoe replicas (b), microcrystalline carbonate (c)

This material was applied to the fabrication of homogeneously white building and archeological formats found in destructs of Wysoka Gorka (Fig. 4) as well as most likely to the production of white glazed tiles (Fig. 5 and 6) found in Cholm, Stolpie and Bielawin.

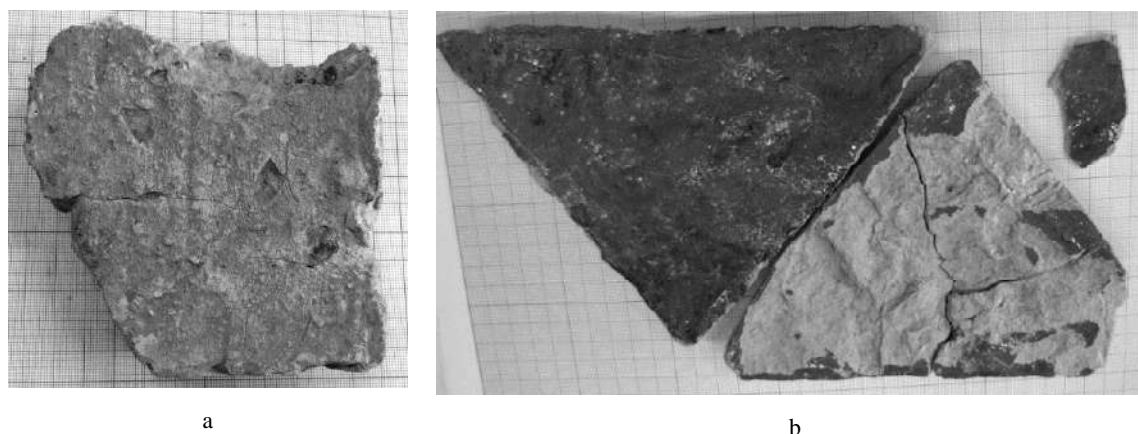

Fig. 4. Building materials obtained from materials synthesized from Cholm chalk. Fragment of a brick or architectural detail (a), glazed tiles (b)

Analysis

The materials taken from retort underwent the research: writing chalk, partially modified chalk with replicas of horsetail as well as microcrystal carbonate material (Fig. 3). Phase studies were performed with the use of polarizing optical microscope, electron microscope SEM and X-ray diffraction. The chemical analysis in the micro area with the use of electron microscope SEM with EDS module was also carried out.

Cholm writing chalk is a typical loose biocalcarenite of dominating hole saw bioclasts in its structure (Fig. 5). In mineral terms, it is a pellicle calcite (above 95 % of CaCO₃) with an insubstantial admixture of loamy minerals, quartz and iron sulphides. It is a soft rock, subject to liquification after adding water and prone to be molded in the plastic state.

The material, in the middle part of retort (Fig. 3, b), is in light grey and white, harder and more bound than the chalk as well as it is not susceptible to plasticity after adding water. There are a lot of stem replicas of plants with segmental structure and longitudinal ribs. In the view of scanning microscope, the structure of horsetail surface is clearly legible (Fig. 6).

In the chemical content of this material, a considerable increase of silica share is noticeable (Fig. 7).

In the microscopic view, strong amorphization of chalk structural elements (bioclasts), cement binds creation and embryonal crystallization of calcite are significant components (Fig. 8).



Fig. 5. Biomorphic structure of Cholm chalk writing in the image of scanning microscope

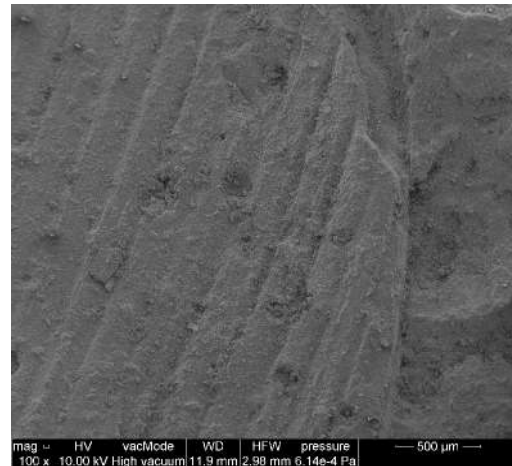

Fig. 6. Replica of the surface of a horsetail in a carbonate matrix. Image from a scanning microscope

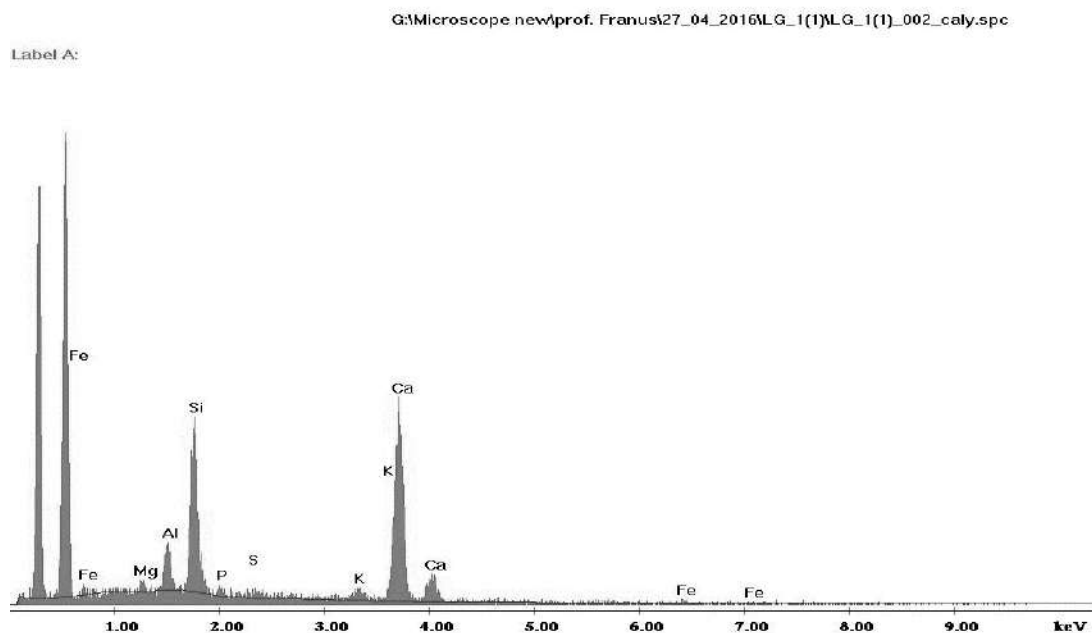

Fig. 7. Results of chemical analysis of EDS SEM plastic with replicas of horsetail stems

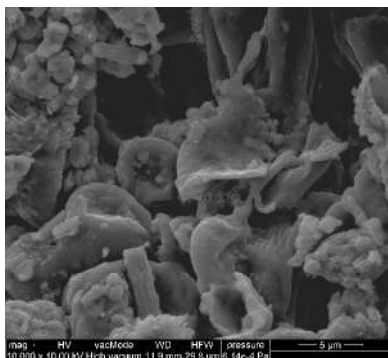

Fig. 8. Amorphisation of chalk and initial calcite crystallization

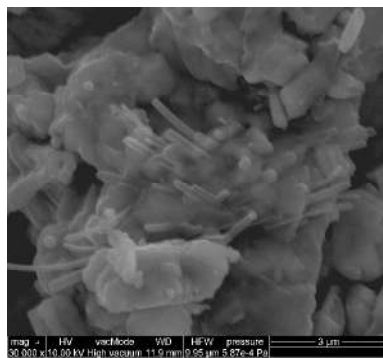

Fig. 9. Steric silica mineralization on calcite crystals

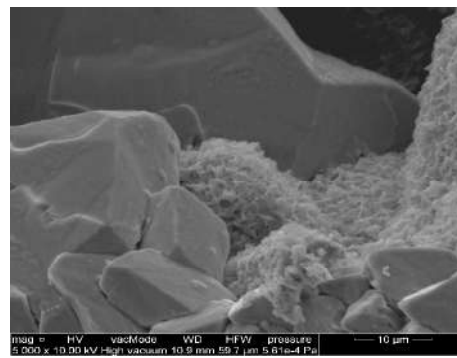

Fig. 10. Crystalline construction of the material obtained by petrified chalk writing

In the microscopic view, the steric capillary silica mineralization (max. 0,1 μm in diameter and 2–3 μm in length) could also be observed, they bind microcrystals of calcite of dimensions to max. 5 μm (Fig. 9). Silica is opal and microcrystalline in its nature. This petrographic material can be defined as silicated limestone having its counterpart in Jurassic massive limestone.

The material from the bottom part of retort (Fig. 3, c) is macroscopically light yellow and white without distinct structural and textural principles. It is cracked along with the shell surface of unbundling. The material is hard, while stroking it makes soundless noise, In addition, it is fully durable in water.

In the view of scanning microscope, structurally this material is fully crystallized (Fig. 10). Calcite microcrystals of the dimensions 5–20 μm automorphically adhere tightly to each other.

In the spaces between calcite crystals, there is silica grouting of distinct crystalline structure and cellular texture (Fig. 11).

Calcite has got clear and symmetric diffractive lines, which indicates its well ordered structure. Silica within the angle range of 20–25⁰2 θ produces diffractive lines characteristic for opal-CT (cristobalite/tridymite) (Jones, Segenit, 1971). Semiquantitative determination of contents of mineral phases on the basis of their diffractive lines enables establishing the calcite content of about 90 % and silica 10 %. This material can be petrographically (mineral and structurally) defined as silicated fine-blastic marble.

Conclusions

Performed phase studies on materials taken from the object which was operationally defined as retort, confirm their carbonate nature. They are the transformation recordings of soft dissolveable writing chalk into the material similar to rocky limestone until obtaining the material with technical values close to marble. It can be inferred from the conducted archeological observations and phase studies that the aim of alchemic activities was to obtain (transmutation) from the soft white chalk, the material which could be a substitute for, unavailable in this region, white building stones (alabaster, limestone, marble). Chalk is generally available white rock in Cholm and surroundings, however, due to the lack of durability in the changing weather conditions, it is totally useless to construction and architectural purposes. The petrification of chalk was performed by recrystallization of its biomorphic structure within the frame of hydrothermal processing in the atmosphere of amorphous silica whose source was a horsetail. On the basis of the content of silica in the hard material and the silica content in the horsetail at the level of 6–8 % in the dry matter, it can be assumed that about 20–30 % of horsetail additive was used to chalk suspension. Chalk petrification was performed by recrystallization of its biomorphic structure in terms of hydrothermal processing in the environment of amorphous silica whose source was the horsetail. On the basis of silica content in the hard material and silica content in the horsetail at the level of 6–8 % in a dry matter, it can be assumed that there was about 20–30 % of horsetail additive to chalk suspension. During the process of boiling, silica was released and became the transformation inhibitor of calcium carbonate which, through the initial phase of amorphization, transformed into the completely crystalline form. The morphology of

horsetail in the conducted process underwent full annihilation. In addition to recrystallized calcite, silica also became a structural and cement element of created material within the frames of opal transformation into the crystalline forms of cristobalite and tridymite (opal CT).

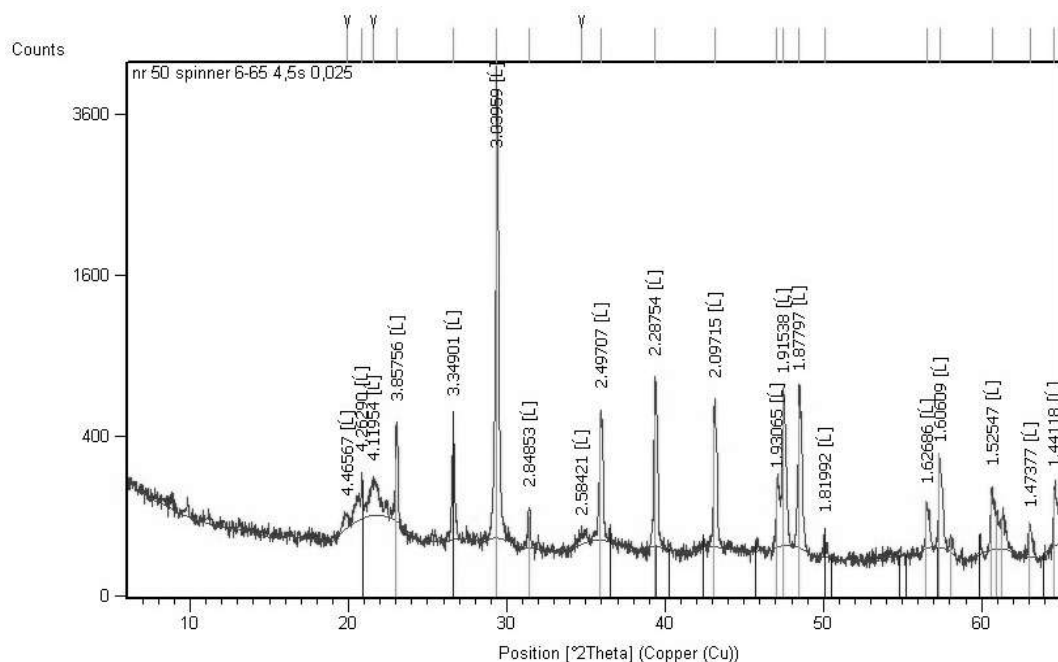

Fig. 11. Diffractogram of hard material

These experiments were performed also using other raw materials that enabled obtaining similar materials tinged with green or red. Undoubtedly, this process was carried out in the hydrothermal conditions. The forms of construction materials (brick, tiles) were obtained by casting from a slurry or plastic moulding. These fittings gained technically enough strength after complete cooling and evaporation. Full strength and durability were obtained after longer maturation. Among found construction materials (brick, tiles), medium hard materials dominate, thus from the phase of biogenic calcite amorphization. The extension of the process, or increase of parameters (e.g. pressure) resulted in obtaining harder materials, however, subject to crack destruction, which could be observed in the material from the bottom part of retort. The process itself was most likely performed in an open tub, thus in the conditions of normal pressure. Nevertheless, it is not excluded that the process was conducted in a closed autoclave (e.g. copper or lead). This can be explained by the continuation of archeological research in this area and more thorough material studies.

Alchemic search for petrification approach of writing chalk in 13th century in Cholm resulted from ideological needs, the aim of implementation of white construction elements of sacral and residential buildings at the lack of these materials due to political and economical possibilities of the investor, Daniel Romanowich.

The model for green and white buildings created here before the fire in 1256 as well as the attempts to recreate them, was the implementation of co-called Pisan School from the 12th century but in other architectural forms (Fig. 12, 13).

Inspiration for the search could be the appearance of white Chinese porcelain on European market, as well as the achievements of west European alchemy coming to Cholm.

The applied hydrothermal technology of chalk processing with the addition of horsetail, enabled transformation of this soft rock into the material similar to massive limestone and silicified marbles.

It has not been explained yet whether Daniel managed to develop the production of these artificial stones to the scale sufficient to open only the Church of St. John Chrysostom, however, without a doubt, this experiment is a pioneer in processes of silicate autoclave which are considerably more recent technologically.



Fig. 12. Baptistery in Pistoia. Main entrance with green and white stone decoration. Photo Lorenzo Lovato

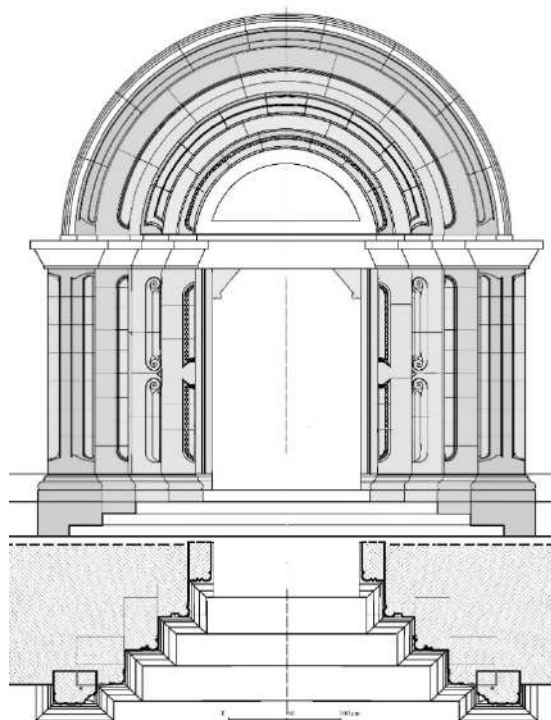

Fig. 13. Hypothetical reconstruction of main portal of St. John's Church of the king Daniel's residence in Cholm. Author M. Bevz

References

- [1] Bevz Mykola, Buko Andrzej, Gazda Lucjan, Golub Stanislaw, Lukomskiy Yuriy, (2015). "Materialy i technologii w architekturny biografii mista (na prykladi mista Cholm u Polshchi)". Zberezhenia istorychnoji zabudowy tsentra Odesy shliachom vkluchennia do osnovnoho spysku Vsesvitnoji spadshchyny UNESCO. Materialy II mizhnarodnoji naukovopraktychnoji konferentzii. 24–26 chervnia. Odesa, Astroprint, 136–147.
- [2] Buko Andrzej, (2016). Źródła pisane i archeologia: przykład góry katedralnej w Chełmie. Kwartalnik Historyczny. Rocznik CXXIII, 2 PL ISSN 0023-5903.
- [3] Dąbrowski Dariusz (2012). "Daniel Romanowich. Król Rusi (ok. 1201–1264). Biografia polityczna". Wydawnictwo Avalon.
- [4] Gazda Lucjan (2016). "Wyniki badań surowców i materiałów budowlanych. Od cerkwi katedralnej króla Daniela Romanowicha do bazyliki pw. Narodzenia NMP w Chełmie" (Red:)
- [5] Buko Andrzej, Gołub Stanisław – Chełm: Muzeum Ziemi Chełmskiej im. Wiktora Ambroziewicza w Chełmie, 213–234.
- [6] Gołub Stanisław, (2013). Dokumentacja z badań archeologicznych w latach 2010–2012. Projekt badawczy Ministerstwa Nauki i Szkolnictwa Wyższego "Zespół rezydencjalno – sakralny na Górze Katedralnej w Chełmie". Chełm.
- [7] Jones J. B., Segenit E. R. (1971). "The nature of opal. Nomenclature and constituent phases". J. Geol. Soc. Australia 18.
- [8] Hutzuliak Roman, Shevchenko Natalia (2015). Chimiko-petrografichni doslidzhennia budivelnych materialiv z katedry Bohorodytzi u misti Cholmi (1 etap). Korol Danylo Romanowych: kulturna i derzhavotvorcha spadshchyna yoho doby. L'viv: L'vivska Politechnika. Vyd-vo: Rastr-7. S. 196–206.
- [9] Lukomskiy Y., Bevz M. (2012) "Badania archeologiczne fundamentow dawnej katedry w Krylosie-Haliczu. Problem konserwacji i muzeumifikacji". XXVIII Konferencja Sprawozdawcza "Badania archeologiczne w Polsce Srodkowo-Wschodniej, zachodniej Bialorusi i Ukrainie w roku 2011". – Lublin: 29–30 marca 2012 r. Lublin, UMCS. S. 26
- [10] Voytovych Leontiy (2014) "Korol Danylo Romanowych: davni i moderni napriamky falsyfikatzii portretu". Korol Danylo Romanowych: kulturna i derzhavotvorcha spadshchyna yoho doby. L'viv: L'vivska Politechnika. Vyd-vo: Rastr-7. 2014. S. 11–32.
- [11] Zygmunt Świechowski (2004). Romanizm, Warszawa, Arkady.

АРХІТЕКТУРНІ ДЕТАЛІ ТА МАТЕРІАЛИ БУДІВЕЛЬ РЕЗИДЕНЦІЇ XIII ст. КОРОЛЯ ДАНИЛА РОМАНОВИЧА У ХОЛМІ

Анотація. У статті проаналізовано будівельні матеріали та архітектурні деталі, отримані під час археологічних розкопок на Високій Гірці в Холмі (сьогодні Хелм, Польща), в районі комплексу резиденції короля Данила Романовича з 13 століття. Домінують тесані блоки з каменю глауконітиту та вапняку.

Глауконітовий камінь у великій кількості знайдено в розкопах. Він слугував будівельним матеріалом для стін у формі тесаних блоків. Такі блоки можна поділити на дві групи: 1 – блоки у формі паралелепіпеда обтесані та шліфовані з усіх сторін; 2 – блоки у формі, наближеній до паралелепіпеда, які тесано та шліфовано лише з лицевої сторони; а решта сторін мають ламану поверхню та груботесану. Особливістю є те, що ці блоки часто використовувалися повторно у пізніших будівлях.

Глауконітовий камінь зустрічаємо також у формі архітектурних деталей з різьбленими елементами. У результаті археологічних досліджень виявлено сьогодні близько 50 таких деталей. Частина з них (близько 20 деталей) належить до так званої колекції П.Покришкіна – з розкопів виконаних у 1911–12 роках у південній частині гірки. Решта деталей виявлені розкопками останніх 8 років.

Усі ці архітектурні деталі можемо поділити на кілька груп: 1). Найчисельніша група – це профільовані наріжні блоки з півваликом (їх налічуємо 8 та ще 5 – у розкопах Покришкіна); 2). Інша група – це профільовані наріжні блоки з четвертною викружкою, півваликом та вертикальними тягами (1 блок та ще 3 таких блоки у колекції Покришкіна); 3). Криволінійні профільовані блоки з четвертною викружкою, яких знайдено три; вони були частиною архівольта арки перспективного порталу.

Аналіз архітектурних форм цих деталей дає змогу зробити висновки про їхню приналежність до таких частин будівель замку: перспективного порталу, обрамлення вікон та дверей, карнизи, колони, капітелі та ін.

Штучний камінь виступає у вигляді цегли та глазурованої плитки, а також значних безформних мас застиглого камяного тіста, що вказують на залишки процесу виготовлення. Матеріали штучні – білі, зелені та різнобарвні. Вони доповнюють застосовані тут галицькі алебастри та зелений глауконіт із Холма. Була проведена експертиза білих матеріалів. Їх діагностували за допомогою мікроскопа SEM та рентгенографії. Крім того, був проведений хімічний аналіз мікроструктури за допомогою мікроскопа SEM з модулем EDS. Проведена експертиза показала, що матеріали, про які йдеться, виготовлялися за іншими технологіями, ніж керамічні, але подібні до тих, що використовуються для виготовлення силікатних матеріалів у наш час. Як сировину використовували крейду та біогенний кремнезем, отриманий із хвоща. Процедура скам'яніння проводилася в гідротермальних умовах. У результаті був отриманий матеріал, структурно схожий на мрамур. Успішне виготовлення штучних матеріалів, уможливило реалізацію ідейних структур, побудованих під явним впливом стилю Тосканської школи 13 століття.

Ключові слова: натуральний камінь, штучний камінь, крейда, будівництво резиденції, Холм (Хелм), 13 століття.